

NanoStrike™

technology

First Line of Protection Against Airborne Viruses and Bacteria

NanoStrike™ is a patented nanotechnology designed to inactivate all airborne microorganisms on contact.

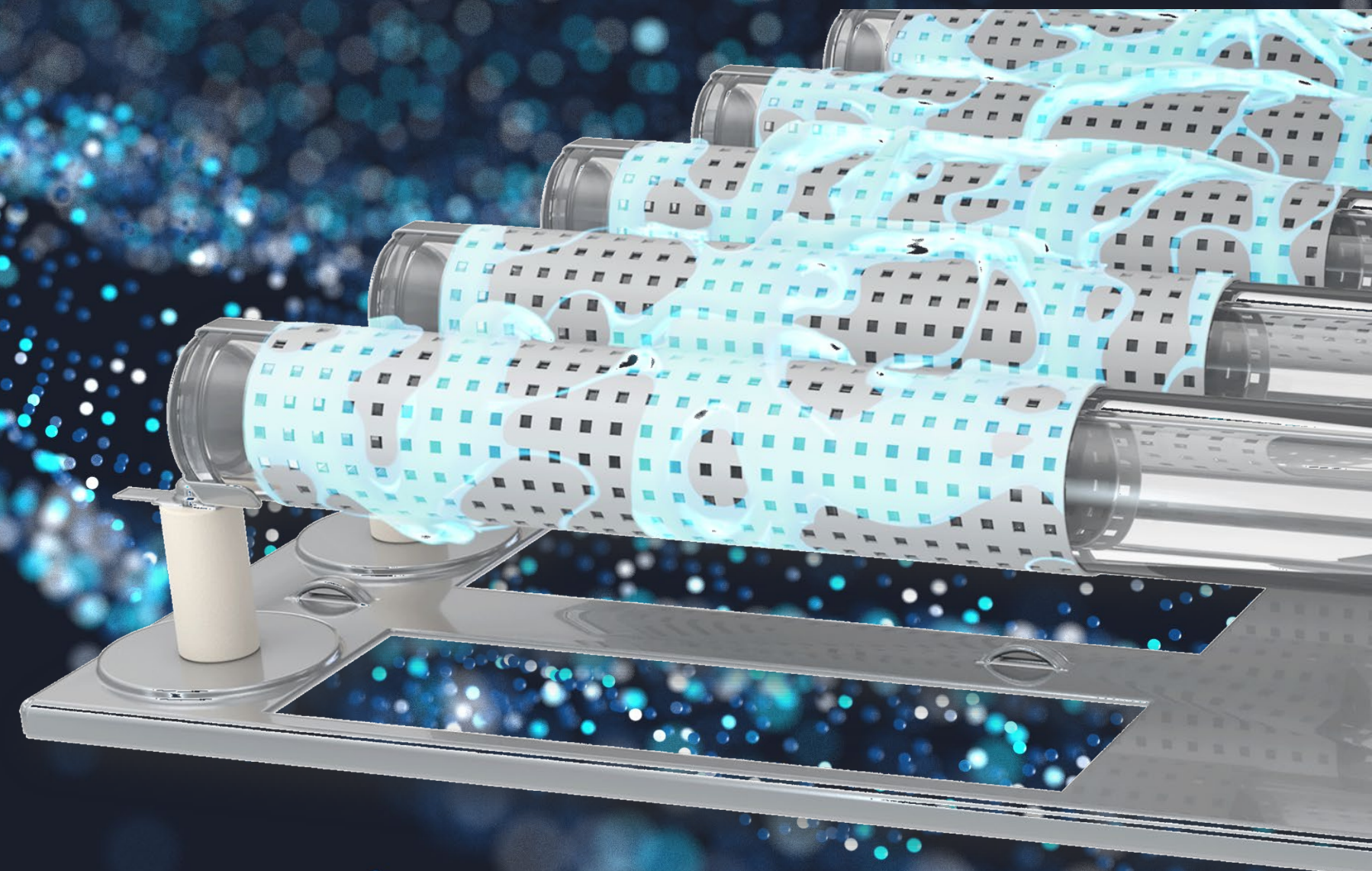

Plasma – The Fourth State of Matter

Plasma is often called “the fourth state of matter,” along with solid, liquid and gas.

When you apply energy to a solid (usually in the form of heat), it becomes a liquid.

When you apply energy to a liquid it becomes a gas. Finally, when you apply energy to a gas it becomes a plasma.

So, in very simple terms, plasma is an energized gas – a soup of positively charged particles (ions) and negatively charged particles (electrons).

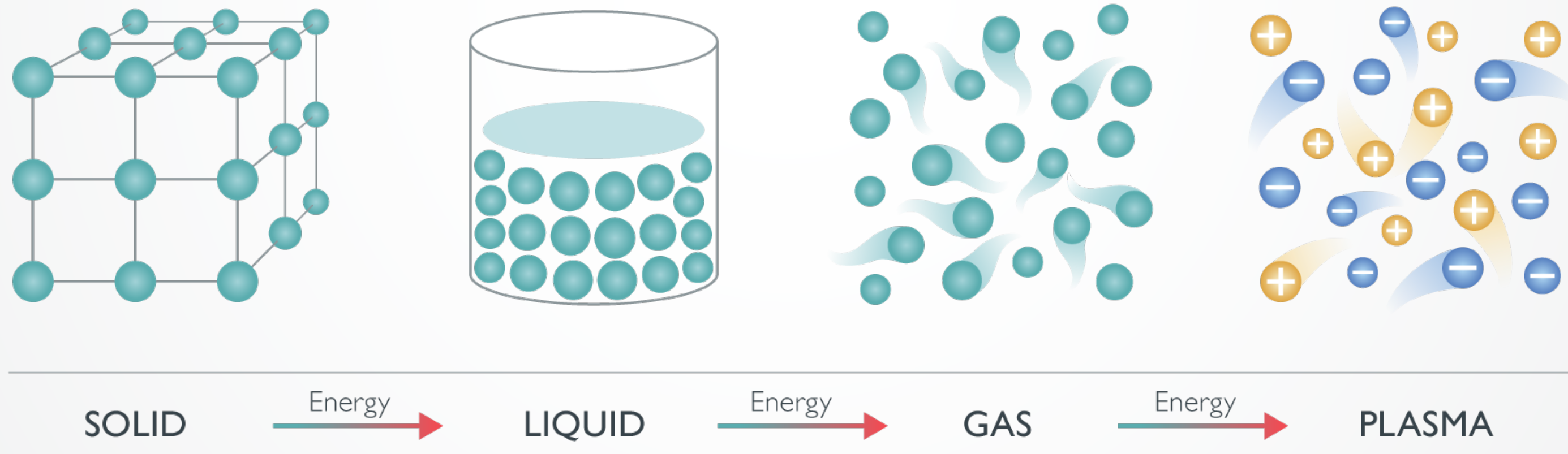

Plasma – Examples in Nature and Healthcare

Plasma can be found in nature. For example, lightning strikes, the sun, solar wind and the aurora borealis.

In recent years there has been a significant emergence of plasma technology being utilized in medical devices and clinical care.

Applications include sterilization of implant surfaces, surgical instruments and suites, as well as being applied directly to wounds and skin to expedite the healing process.

Nature

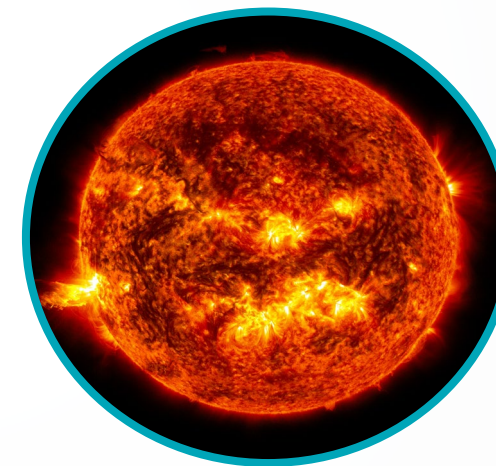

Healthcare



NanoStrike Technology – What is it?

NanoStrike technology is an exclusive form of atmospheric, low-energy, non-thermal (cold) plasma of the dielectric barrier discharge (DBD) type – “the unique power of one”.

Unlike ionization centric plasma DBD, the unique, patented, low power, NanoStrike technology inactivates viruses, bacteria and fungi at the DNA level.

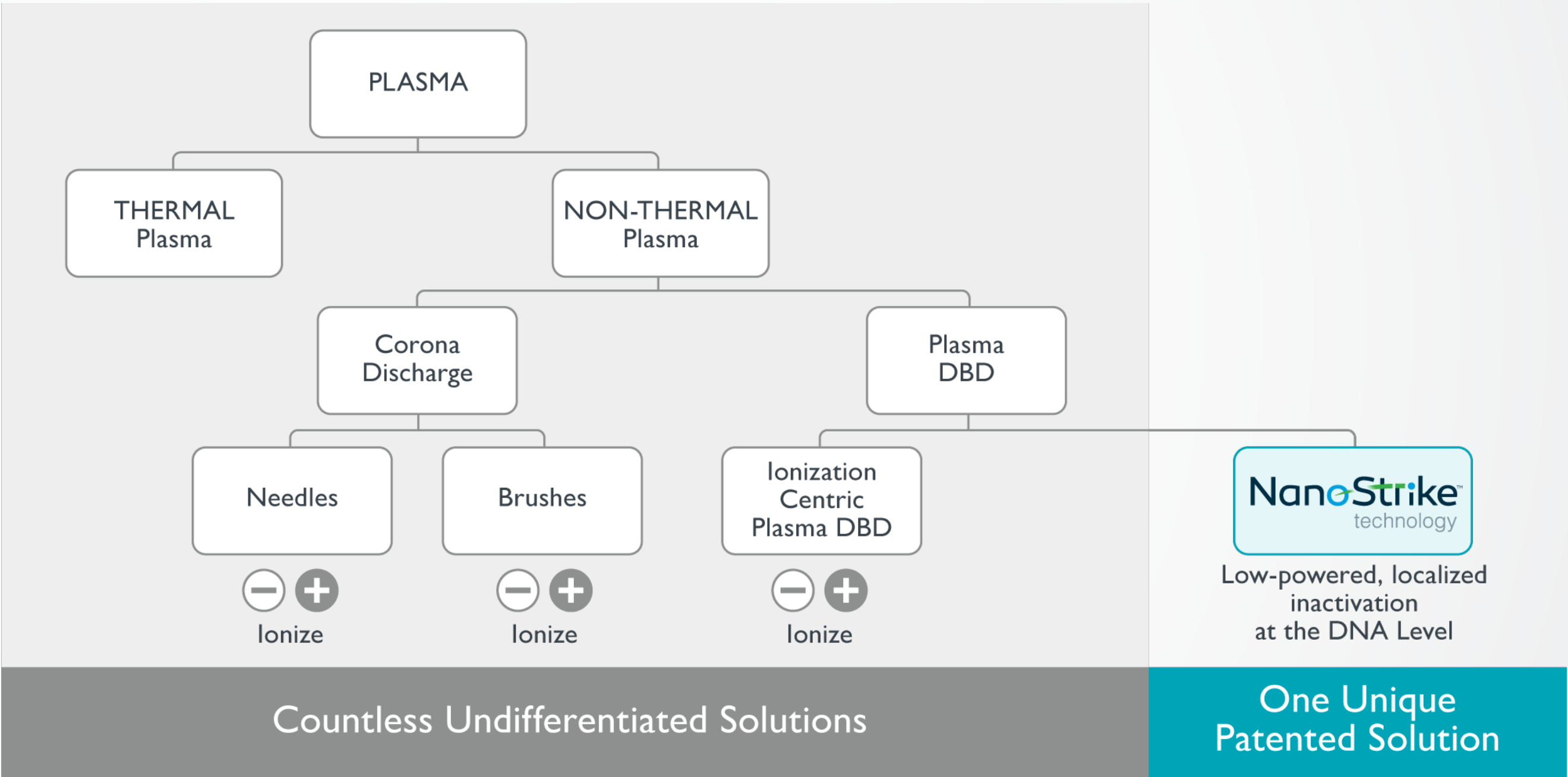

NanoStrike Technology – What does the name signify?

NANO – The technology destroys nanosized microorganisms, less than 1nm in diameter, using a range of concurrent pathogen inactivation processes occurring in the nanosecond timeframe.

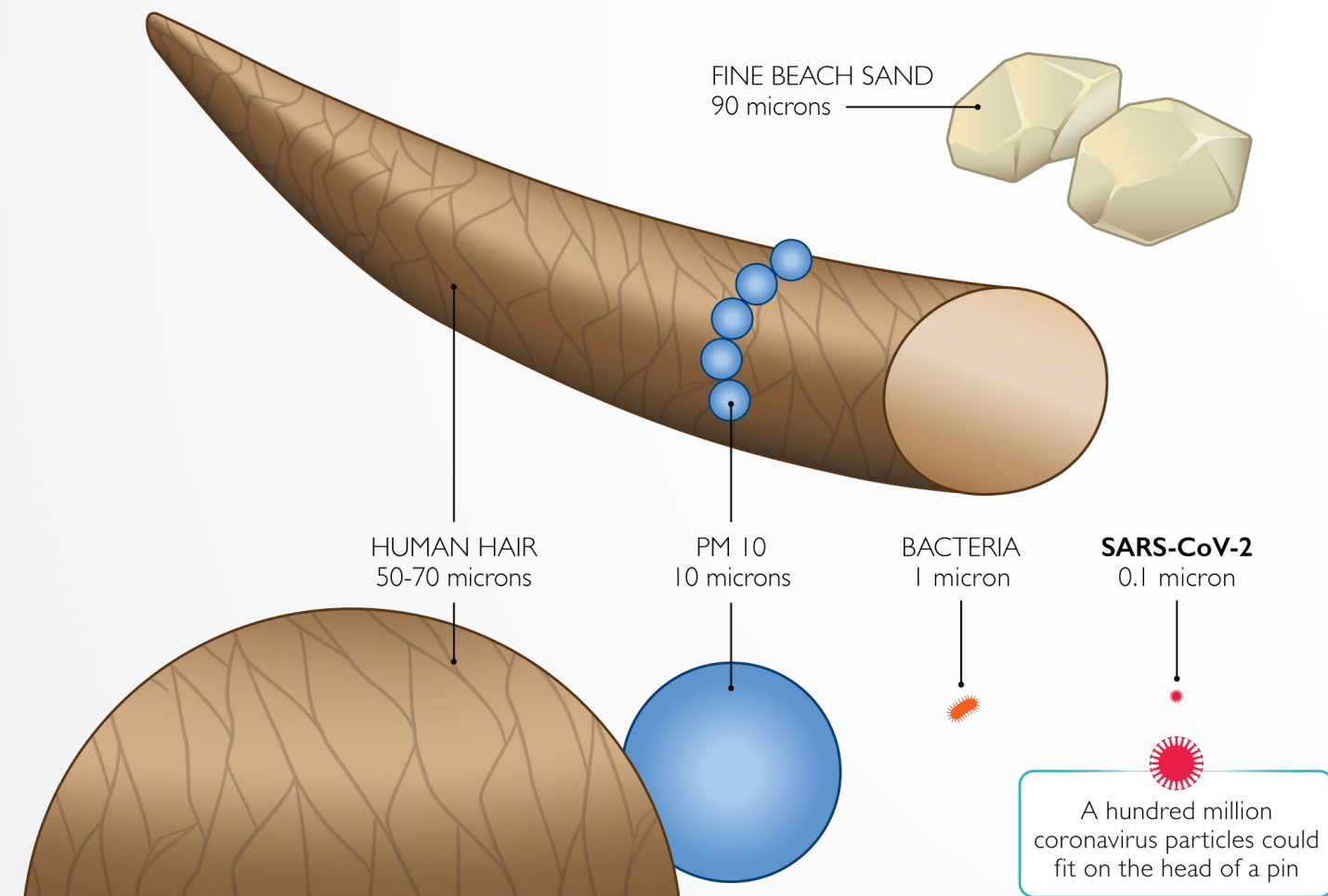

STRIKE – Strike reinforces the immediate destructive effects that the plasma has on pathogens at the DNA level — effectively inactivating airborne viruses, bacteria and fungi with one strike.

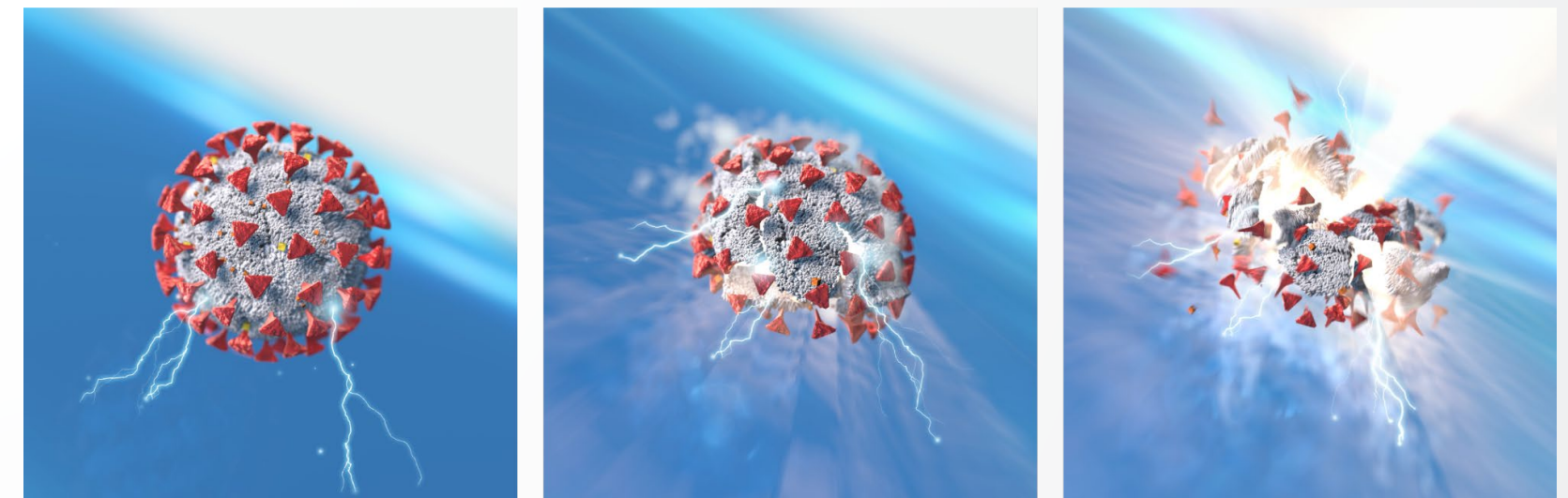

NanoStrike Technology – How is it applied?

NanoStrike technology utilizes plasma coils to provide a powerful strike to all harmful airborne pathogens – such as viruses, bacteria and fungi – as they pass through the plasma field, obliterating them at the DNA level.

Microorganisms are exposed directly to the plasma discharge as opposed to by-products of the discharge as the air flows over the coils. Inactivation occurs on the surface of the plasma coil and/or near the surface as the air flows fully around the outer surface of the coil.



NanoStrike Technology – How is it different?

NanoStrike's effectiveness lies within its ability to inactivate nanosized pathogens in a localised way.

NanoStrike's range of physical concurrent pathogen inactivation processes occur on or near the surface of the plasma coil, as the air flows fully around the outer surface of the coil.

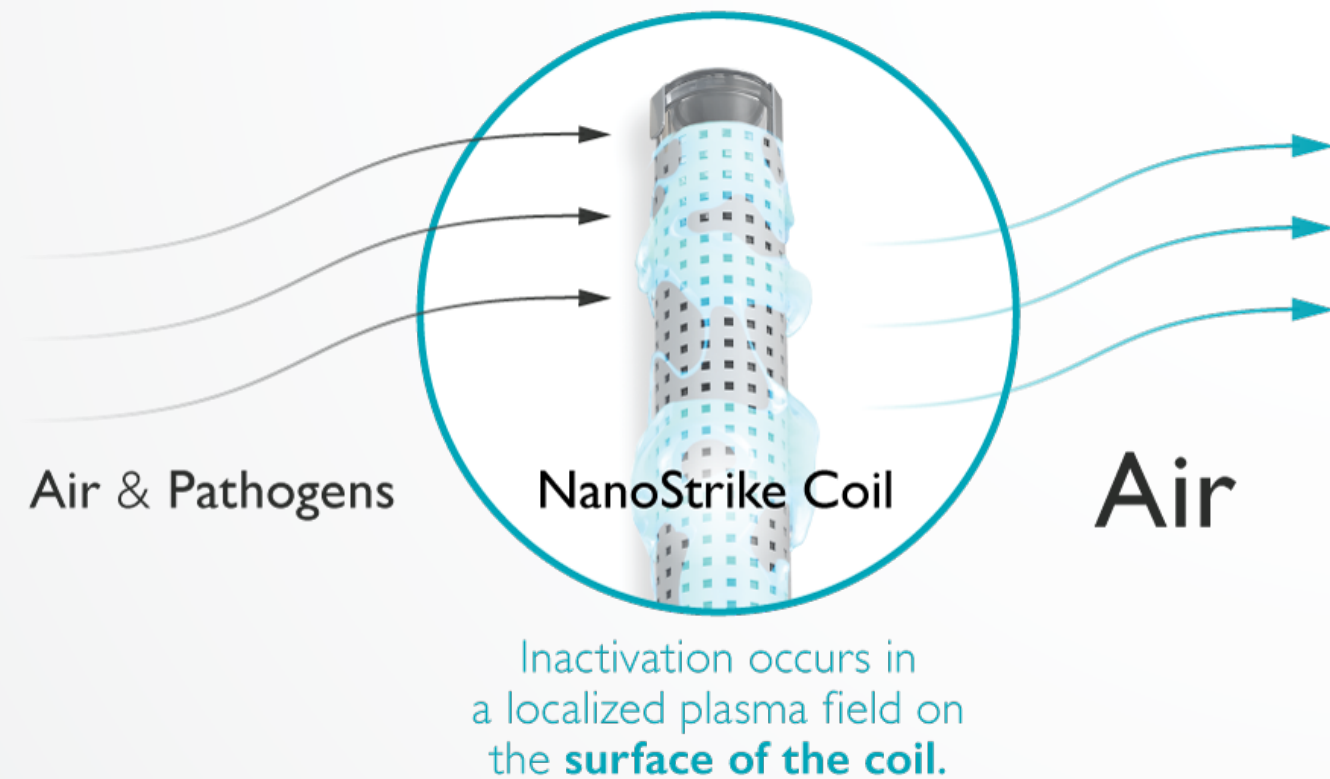

Other plasma technologies — such as ionization — release ions into the air. The ions bond with pathogens, causing them to cluster and making them heavy, so they fall out of the air within an occupied space, landing on surfaces and objects, potentially creating sources of contamination or becoming airborne again through everyday activities.

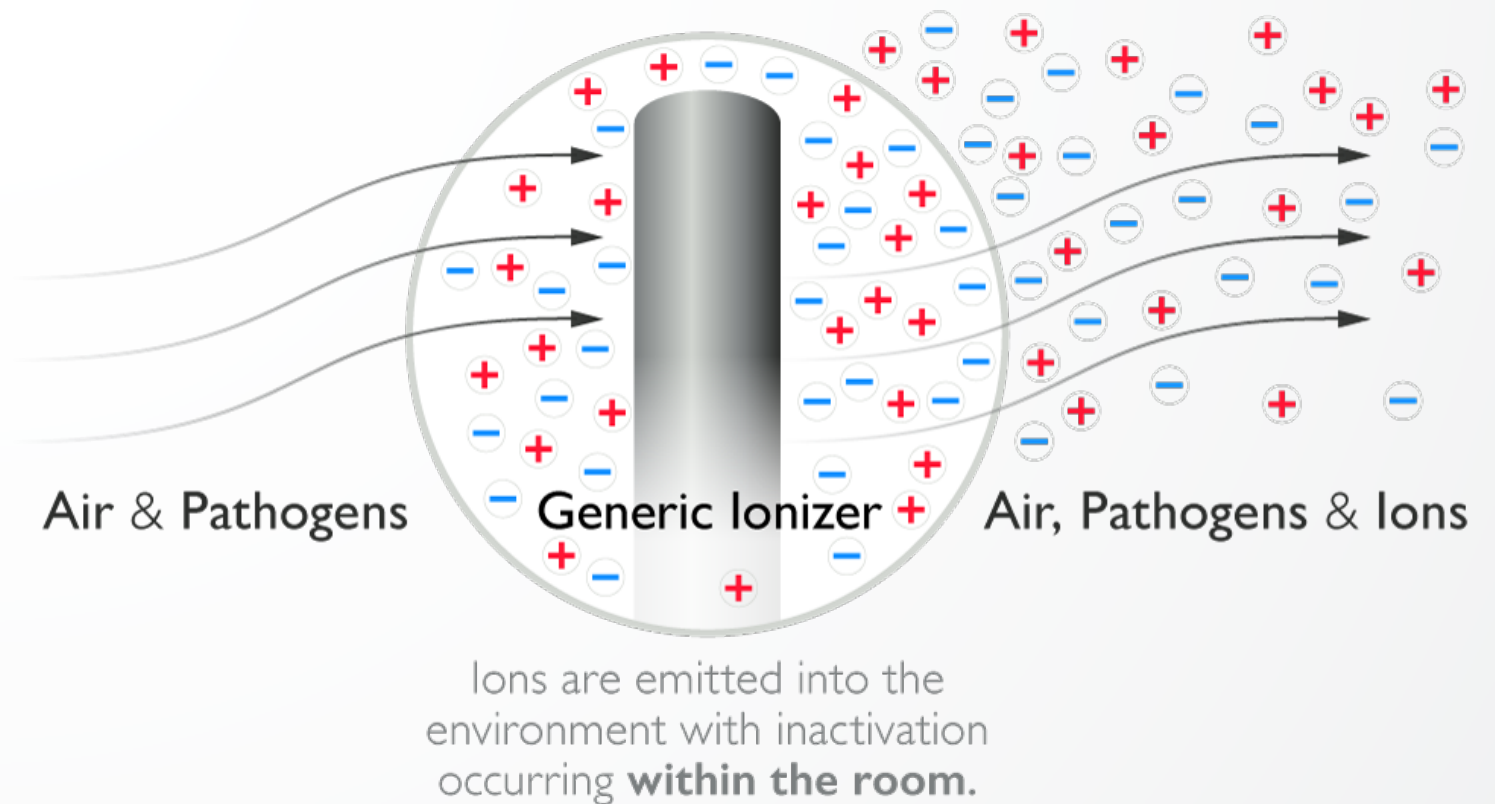

NanoStrike Technology – Combines multiple concurrent inactivation processes

- NanoStrike utilizes a comprehensive range of physical concurrent pathogen inactivation processes, working in unison at the nanosecond level, to dis-infect the air.
- These processes occur in a localized way, on or near the surface of the plasma coil (ie. a few millimeters from the coil itself), with no by-products being released out into the air.
- As these processes happen simultaneously, many millions of times per second, it seems to the human eye that a virus, bacteria or fungi is obliterated in one powerful strike.

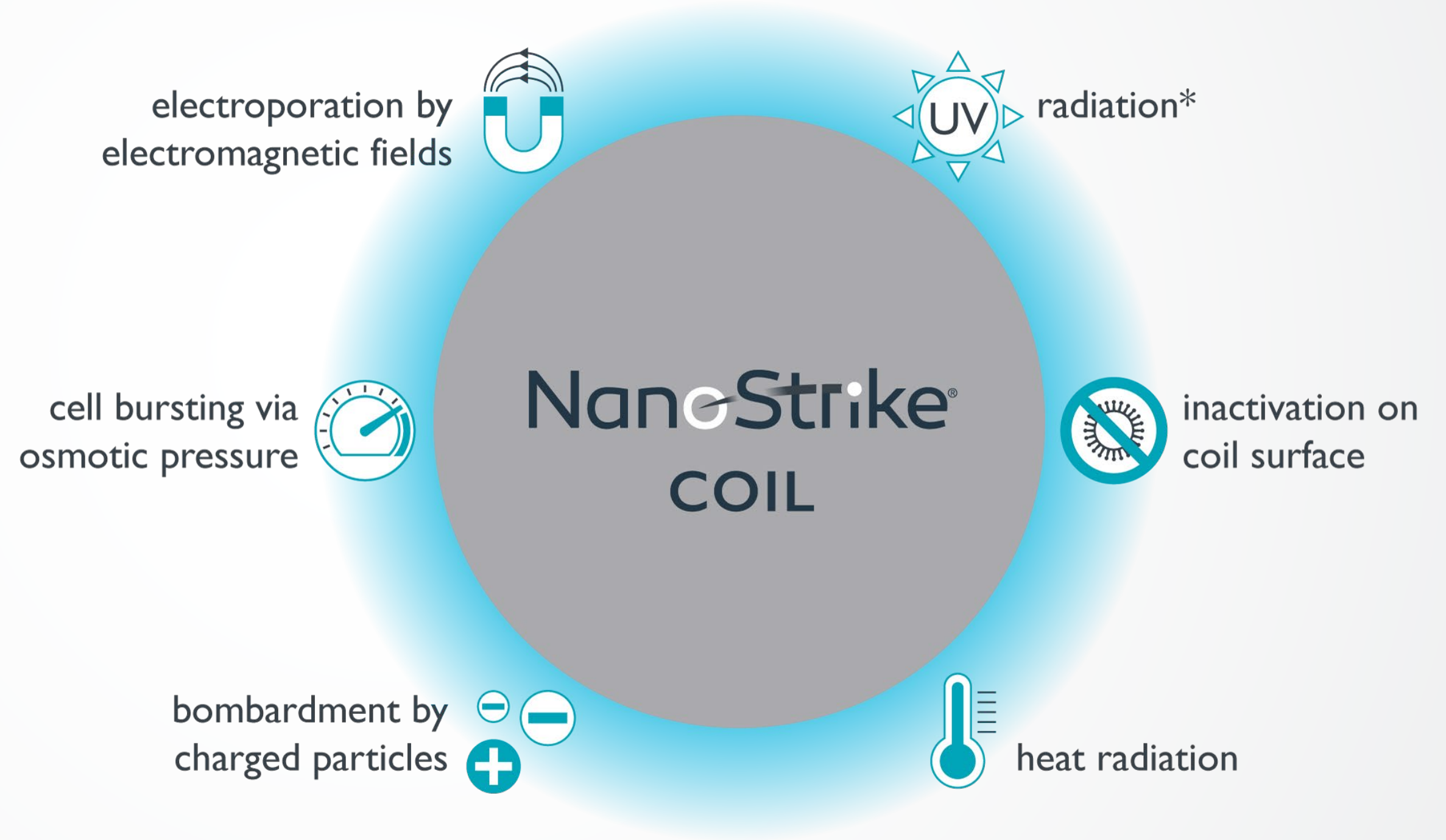

NanoStrike Technology – The science behind NanoStrike dis-infection process

MICROORGANISM'S
PORES / CHANNELS

INTERNAL DAMAGE
TO MICROORGANISM

MICROORGANISM
COLLAPSES UNDER
OSMOTIC PRESSURE

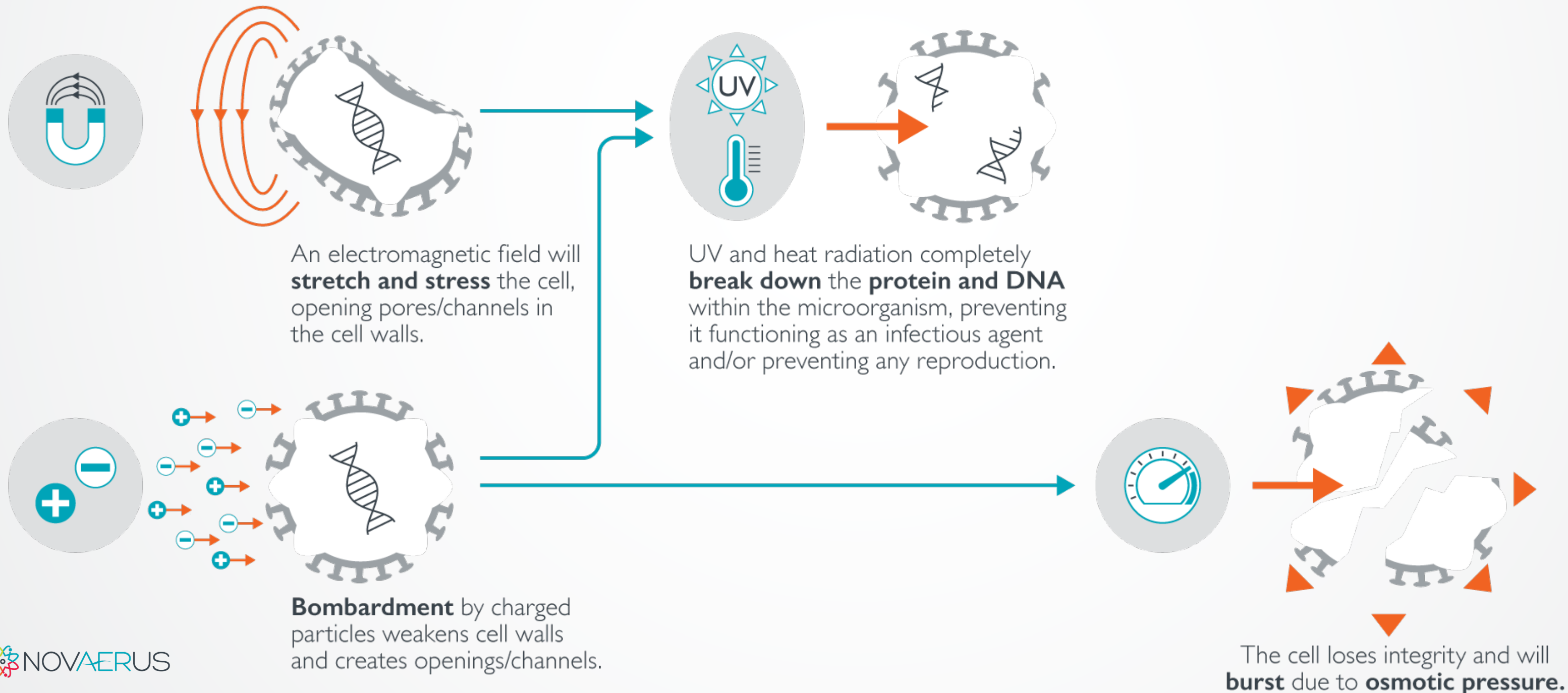

NanoStrike Technology – The competitive advantage of multiple concurrent inactivation processes

The combination of these concurrent inactivation processes delivers:-

- The fastest inactivation time of any technology – destroying pathogens in the sub-second timeframe.
- Complete destruction of the DNA and protein of a pathogen ensuring it cannot infect a person or reproduce.
- Bursting of the pathogen cell, ensuring no self-healing, in which the DNA or protein is repaired.
- Inability of the pathogen to develop Anti-Microbial Resistance (AMR) to NanoStrike.

Technology	Inactivation and Removal Processes							
	Electromagnetic Field	UV	Reactive Agent	Charged Particles	Heat Radiation	Osmotic Pressure	Trap	Adsorb
NanoStrike™ Technology	●	●	●	●	●	●	●	●
UVGI	●	●	●	●	●	●	●	●
PCO	●	●	●	●	●	●	●	●
Unipolar Ionization	●	●	●	●	●	●	●	●
ESP	●	●	●	●	●	●	●	●
Particulate Filtration	●	●	●	●	●	●	●	●
VOC Filtration	●	●	●	●	●	●	●	●
Heat	●	●	●	●	●	●	●	●
Chemical	●	●	●	●	●	●	●	●

● NO ● YES

No other solution delivers such a comprehensive range of inactivation / removal processes, making NanoStrike truly powerful and unique

NanoStrike Technology – Video animation

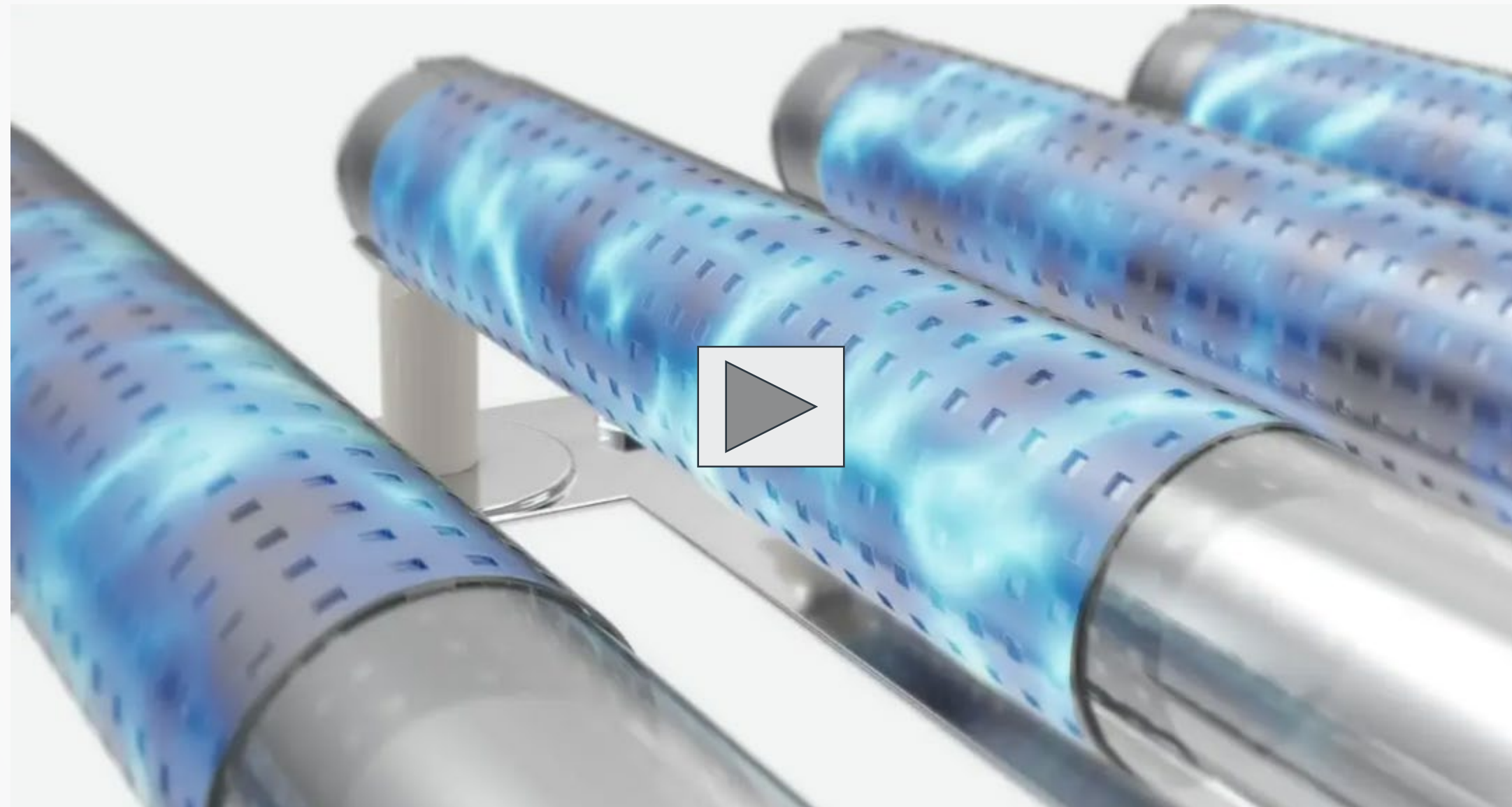

Key Differentiated Competitive Advantages

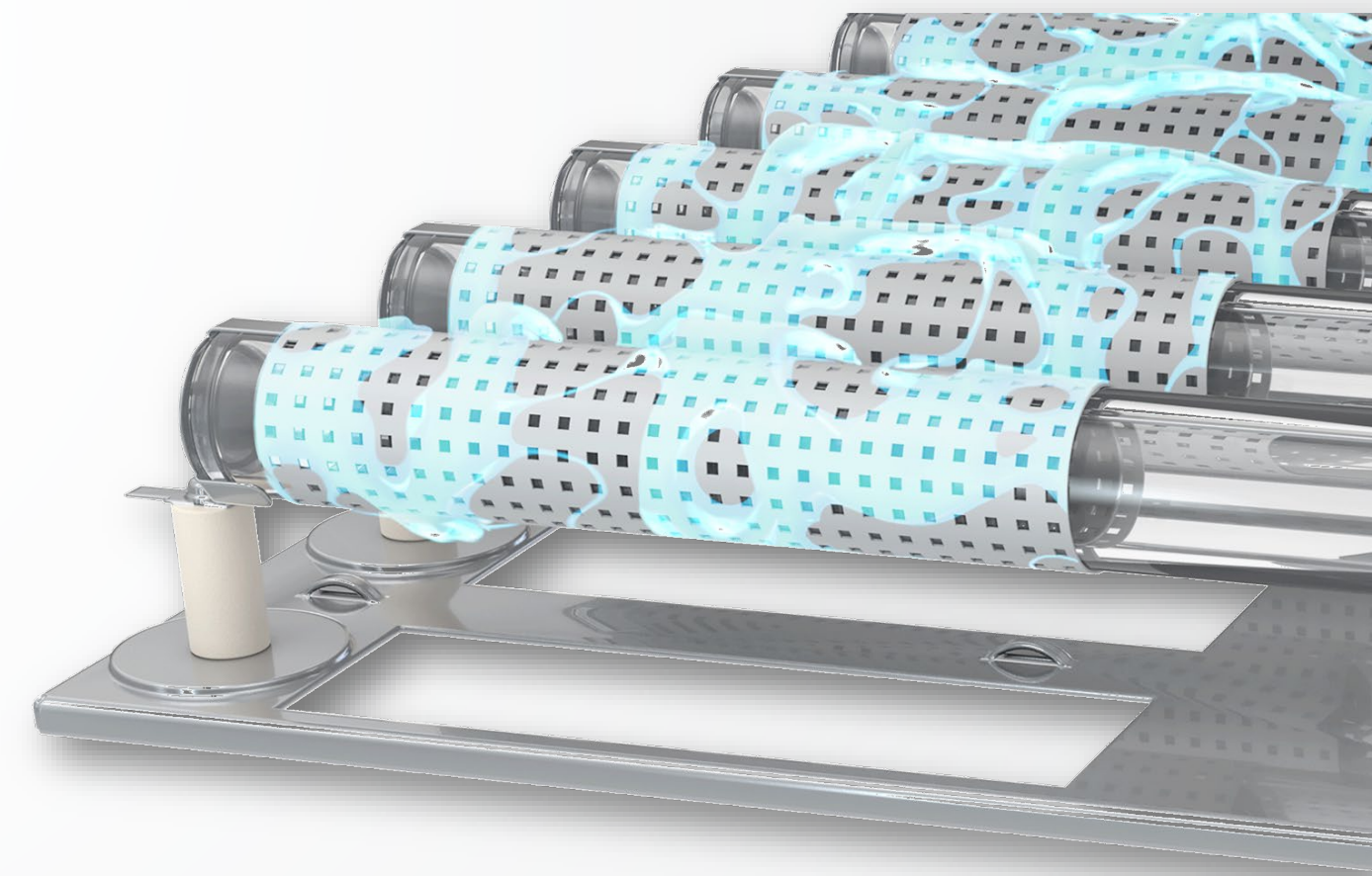

NanoStrike Technology – Delivering true disinfection of airborne pathogens

NanoStrike delivers disinfection of airborne pathogens through its ability to **INACTIVATE** viruses, bacteria and fungi, including their spores.

TRAP technologies can not be considered as disinfection solutions as they do not inactivate the pathogens.

- Pathogens can colonize on these trap-based mechanisms rendering them bio-hazards. They should only be handled by personnel wearing full PPE.
- Pathogens can dislodge from the trap-based mechanisms and thus be released back into the air – creating a new threat of infection.

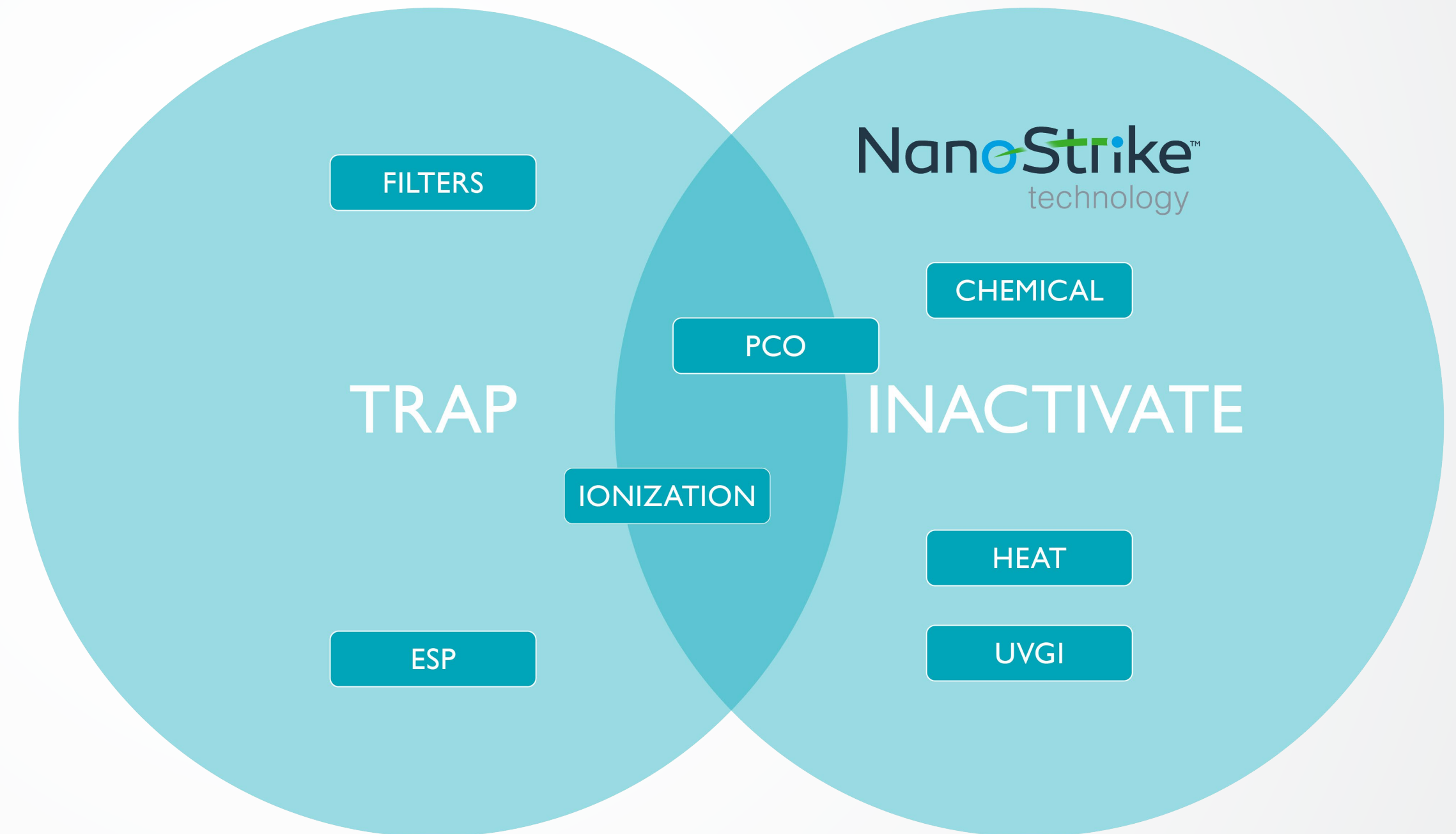

NanoStrike Technology – Inactivating pathogens at the DNA and protein level

By inactivating the DNA and protein of a pathogen, including the RNA of a virus, it prevents

- a human host being infected.
- bacteria and fungi spores from reproducing.
- colonization and future release of infectious pathogens back into air*

*When used with filters, (i.e., Novaerus Defend range)

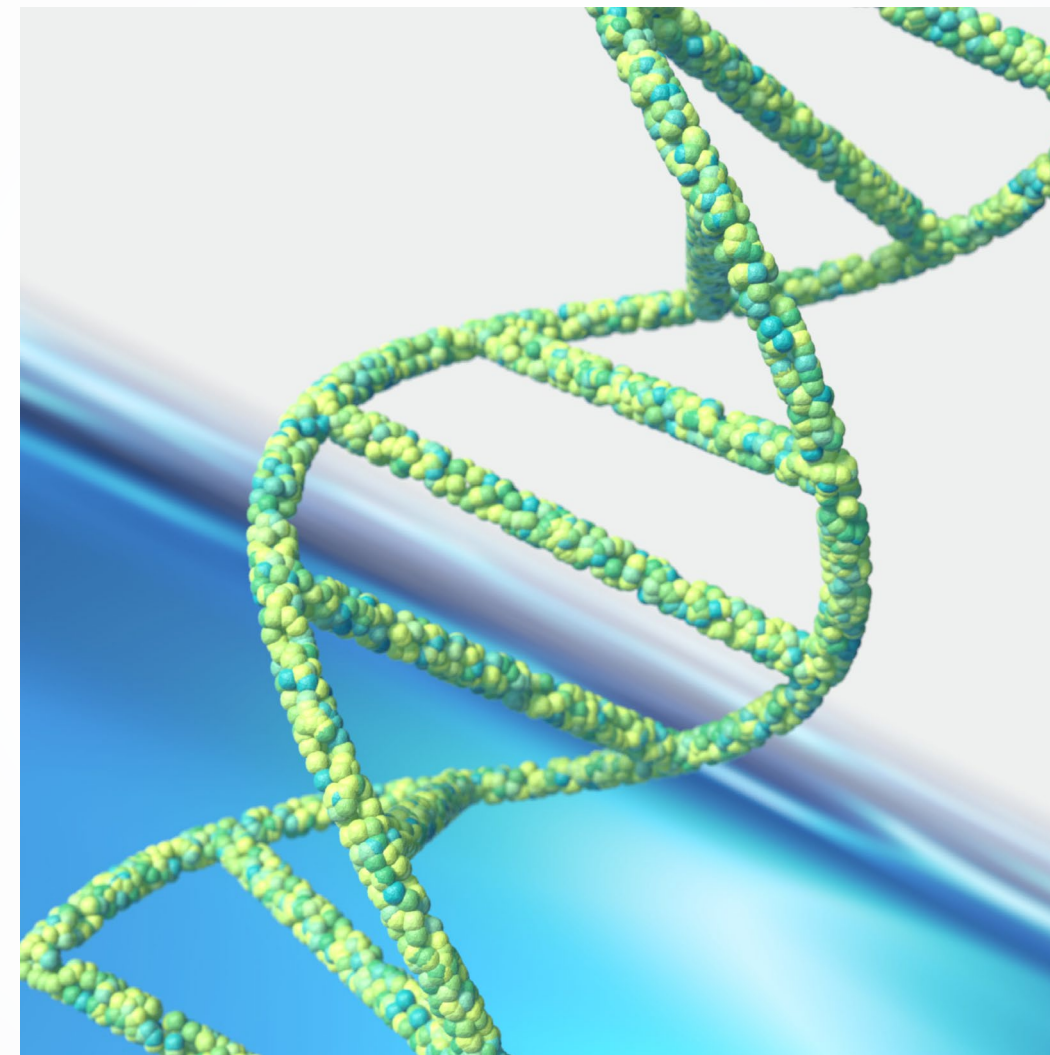

BEFORE NANOSTRIKE

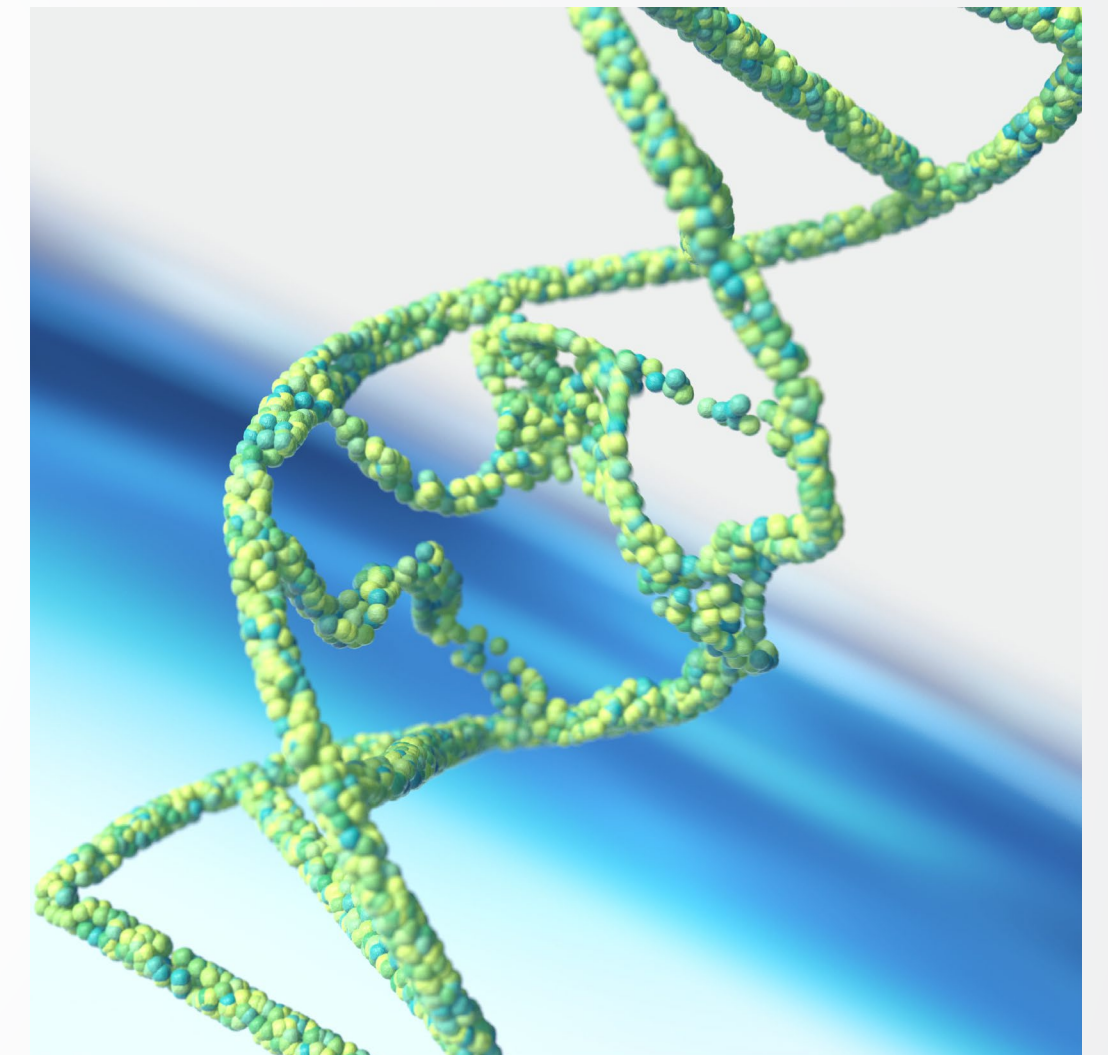

AFTER NANOSTRIKE

NanoStrike Technology – Inactivates the smallest of microorganisms

Proven effective on molecules <1 nm in diameter – ensuring ability to effectively inactivate the smallest of viruses.

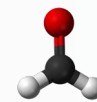

NanoStrike technology has been successfully tested in removing Formaldehyde – with testing carried out by an independent laboratory.

Formaldehyde compound is < 1nm in diameter.

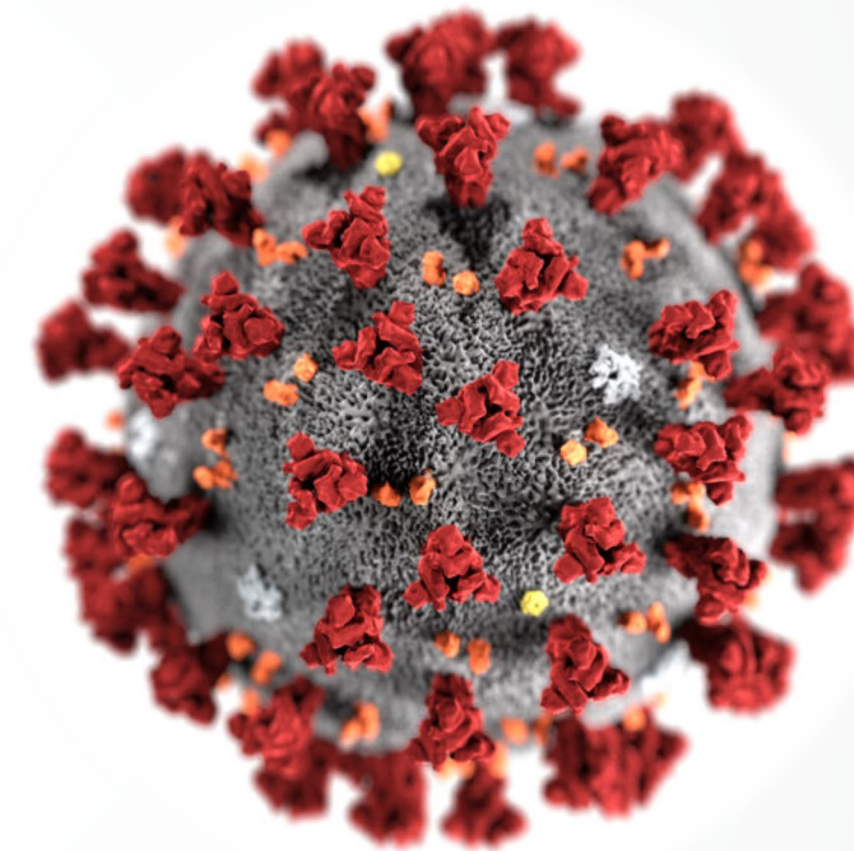

Each SARS-CoV-2 virion is 50–200 nanometers in diameter. – Chen et al (2020)

NanoStrike Technology – Inactivates in the shortest timeframe

No other technology inactivates microorganisms in the sub-second timeframe.

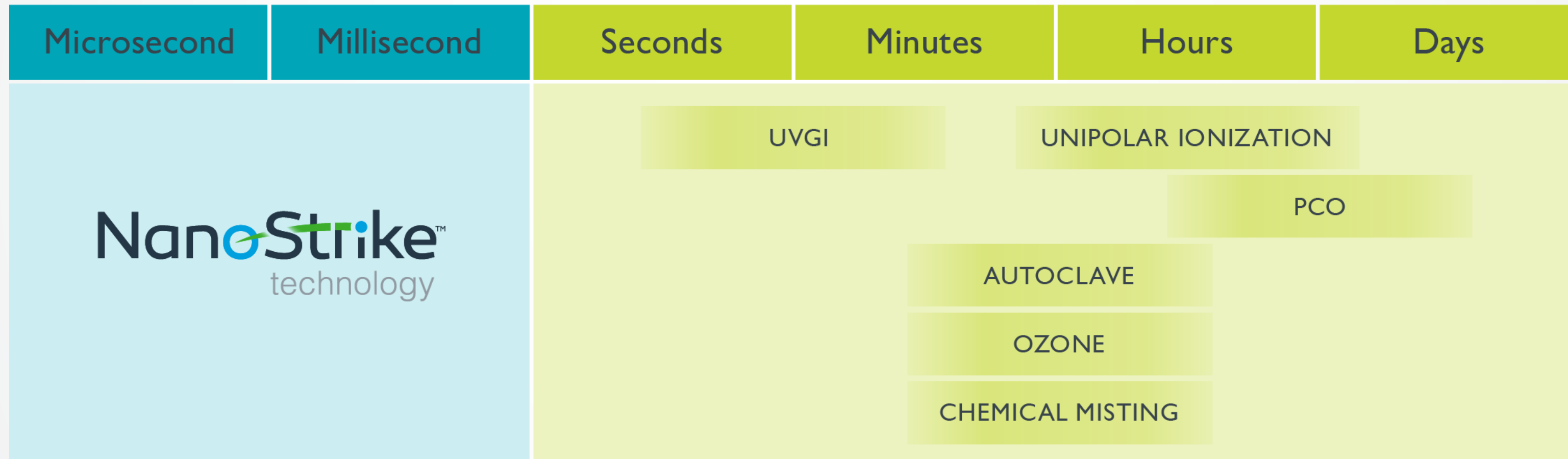

The typical life span of the excited states is about 10 ns.

Maximum exposure rates of pathogen to the NanoStrike® plasma coils is < 11 milliseconds.

Therefore, the pathogen time to inactivation can be concluded to be somewhere between 10ns and 11ms.

NanoStrike Technology – The only air dis-infection technology that bursts a pathogen cell

Inactivate and BURST Pathogen

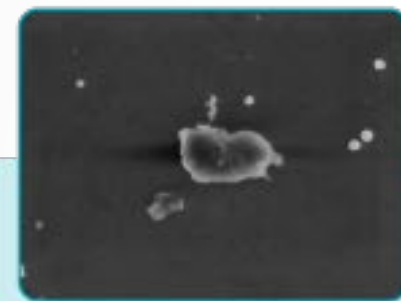

NanoStrike[™]
technology

NanoStrike is truly unique in that it is the only solution, other than antibiotics, to burst the pathogen cell.

Once the cell has burst, there is no way it can self-heal by repairing its protein and DNA.

This ensures a pathogen cannot become viable as an infectious agent at some future point in time.

Inactivate Pathogen ONLY



Other Technologies

UVGI

AUTOCLAVE

UNIPOLAR IONIZATION

OZONE

PCO

CHEMICAL MISTING

NanoStrike Technology – Guarantees no Antimicrobial Resistance (AMR) in future

As NanoStrike technology delivers multiple, concurrent inactivation processes it guarantees there is no opportunity for Antimicrobial Resistance (AMR) to develop over time.

Research¹ has highlighted the threat of AMR developing against single inactivation methods.

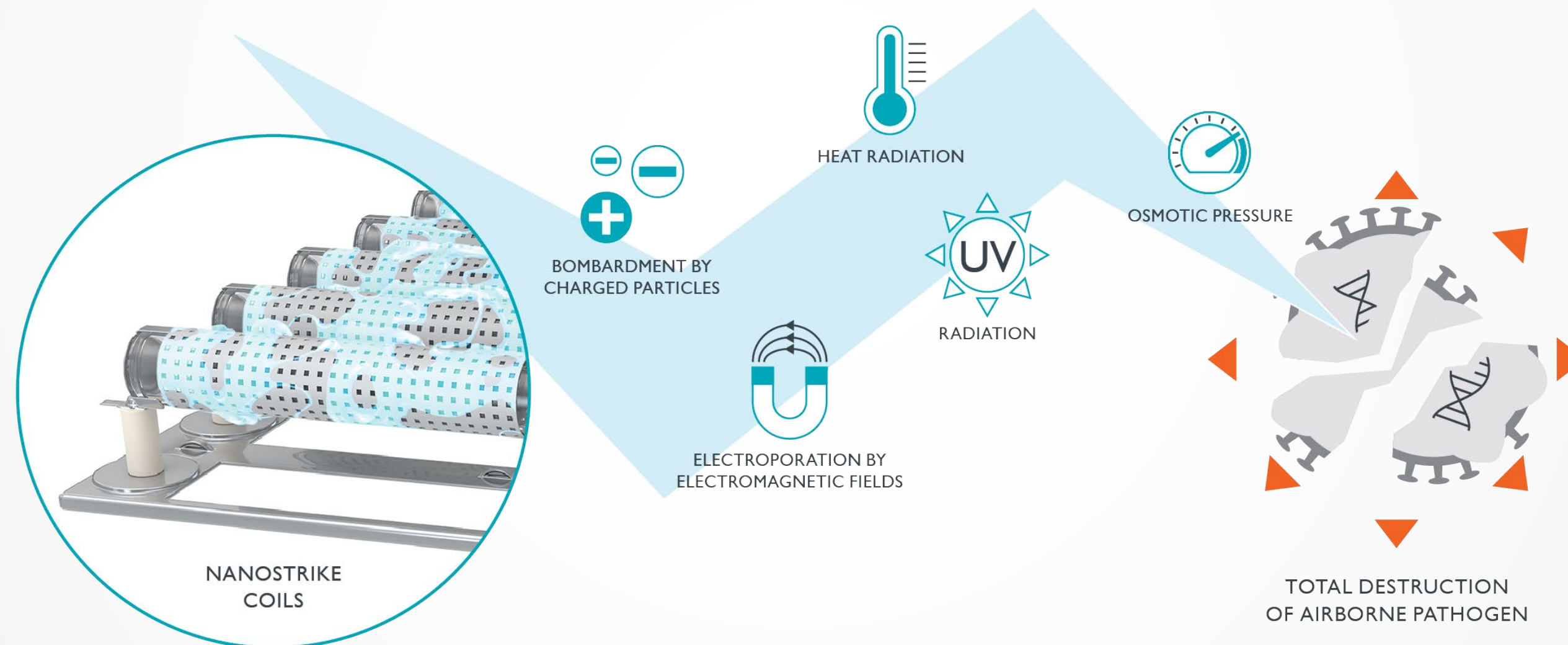

¹ Goldman and Travisano (2011) performed a study on the development of UVGI resistance in *E. coli* cells. Their study indicated that *E. coli* that was continually exposed to UV light over an 80-day period developed a resistance level up to 3X that of a control group of *E. coli*.

NanoStrike Technology – Consistency in efficacy over long operational life

- NanoStrike Technology provides a consistent “as new” performance over the entire operating life of the device.
- Other technologies like filters, ESP, PCO and UVGI have performance degradation over time requiring parts to be replaced or cleaned to achieve “as new” performance levels again.



Note the chart above is directional only, designed to visually indicate the potential performance degradation of competitive technologies. There are different standards for each competitive technology - some solutions utilized in devices may be slightly better and some significantly worse

NanoStrike Technology – Maintains high effectiveness in smallest of form factors

99.99% reduction of airborne viruses is attainable in Novaerus products regardless of their physical size.

Other technologies like filtration, ESP and PCO become less effective as the physical dimensions of the device decreases, as their performance levels are based on maximizing surface area of filters, catalysts and plates, respectively.

DEFEND 1050	PROTECT 800	PROTECT 200
		
<p>SARS-COV-2 * 99.99% in 15 mins</p>	<p>SARS-COV-2 * 99.99% in 300 mins</p>	<p>SARS-COV-2 Not Tested ¹</p>

*Test carried out on MS2 bacteriophage a surrogate of SARS-COV-2

¹As the Protect 200 uses the same technology as Protect 800, (using 1 NanoStrike coil rather than 2) it is safe to state that it will also be successful of destroying SARS-COV-2

NanoStrike Technology – Lowest Total Cost of Ownership (TCO)

- Utilizes ultra-low energy – requiring less power than a light bulb.
- No need to replace expensive components during operating life – unlike every other competitive technology.
- No need for cleaning of components to maintain consistent performance.
- No need for expensive PPE (e.g., goggles, masks, gloves, aprons etc.) to protect service personnel from biohazard risks during cleaning and servicing the devices.
- No disposal costs for biohazard materials.
- True plug and play with no installation, calibration, set up or training costs.

The Iceberg Principle

Calculation Total Cost of Ownership (TCO)

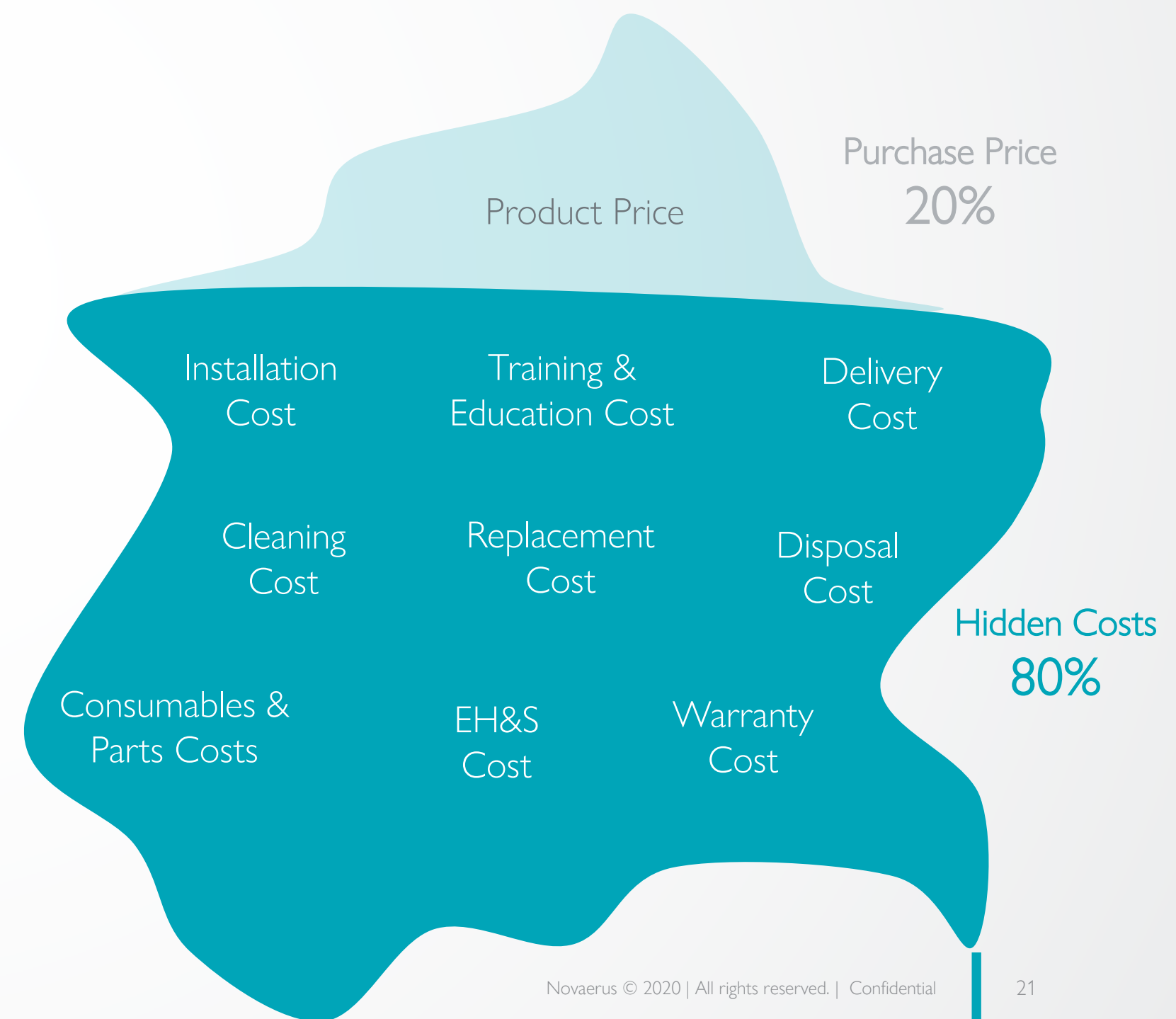



NanoStrike Technology – Powerful but gentle for 24/7 use around the most vulnerable of people

- No harmful by-products
- No colonization of bacterial and fungal spores or endotoxin emissions associated with trap technologies.
- No biohazard waste that can lead to secondary level infection.
- Ultra quiet, with no bright lights to ensure people can remain undisturbed during operation.



NanoStrike Technology – Independently tested and proven

Technology tested in over 30 global, independent laboratories covering a wide range of viruses, bacteria and fungi.

 <p>VIRUSES</p>	<ul style="list-style-type: none"> • SARS-CoV-2 • Influenza A • Phi X 174 • Norovirus¹ • Measles² 	<p>REDUCING live SARS-CoV-2 virus* by 99.99% the virus causing COVID-19</p>
 <p>BACTERIA</p>	<ul style="list-style-type: none"> • MRSA • <i>Bacillus subtilis</i> • <i>Staphylococcus epidermidis</i> • Tuberculosis³ • <i>Escherichia coli</i> • <i>C. difficile</i> • <i>Bacillus Globigii</i> endospores 	
 <p>MOULD SPORES</p>	<ul style="list-style-type: none"> • <i>Aspergillus niger</i> 	

1. Tested on MS2 Bacteriophage, a surrogate for Norovirus.
 2. Tested on Human parainfluenza type 3 (HPIV3), a surrogate for Measles.
 3. Tested on Mycobacterium smegmatis, a surrogate for Mycobacterium tuberculosis.

*Utilizing NanoStrike Technology, Novaerus portable devices can help to remove airborne viruses like SARS-CoV-2 which travel in tiny aggregated droplets that can linger for hours before they settle on surfaces.

NanoStrike Technology – Under the microscope

“The bacteria underwent physical distortion to varying degrees, resulting in deformation of the bacterial structure.” *NASA Ames Research Center*

Two studies, carried out by a team of researchers at Universities Space Research Association (USRA), National Aeronautics and Space Administration (NASA), and Stanford University;

1. Romero-Mangado et al., Morphological and chemical changes of aerosolized E. coli treated with a dielectric barrier discharge, *Biointerphases*, **11**, 011009 (2016)
2. Romero-Mangado et al., Efficacy of atmospheric pressure dielectric barrier discharge for inactivating airborne pathogens, *J. Vac. Sci. Technol. A*, **35**, 041101-1 (2017)

Organisms studied include,

- Bacteria Gram-negative *Escherichia coli*
- Bacteria Gram-positive *Staphylococcus epidermidis*
- Fungi spores *Aspergillus niger*

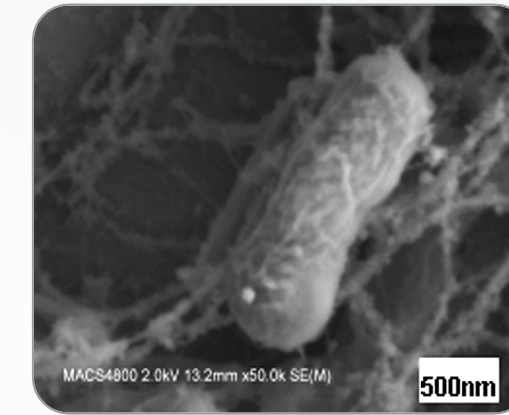

Healthy E.coli Bacteria

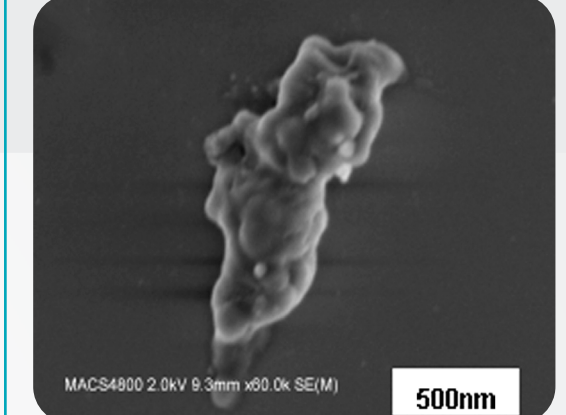

E-Coli after exposure to NanoStrike

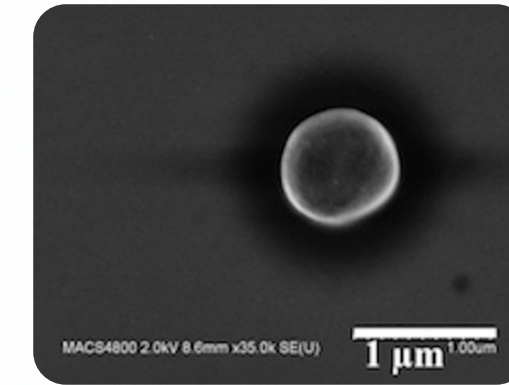

Healthy Staphylococcus Bacteria

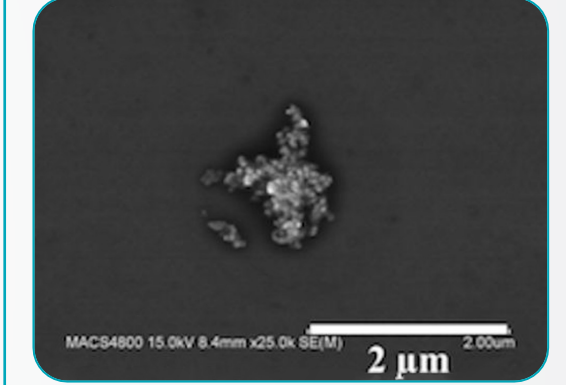

Staphylococcus Bacteria after exposure to NanoStrike

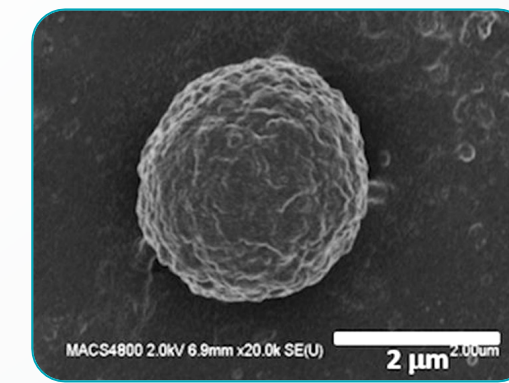

Healthy Aspergillus niger spores

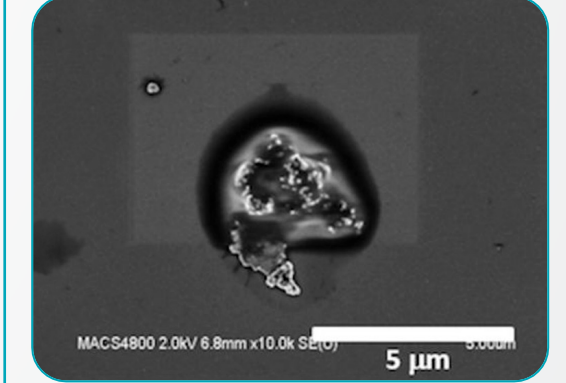

Aspergillus niger spore after exposure to NanoStrike

NanoStrike Technology – Patented and trademarked

- Full patent protection for the technology and its unique application.
- NanoStrike trademarked in a wide range of countries.

Patent Code	Description	Granted Territories	Pending Territories
2054-01	Original Patent (Hallam)	US, China, Germany, France, UK, Netherlands, India	N/A
1316-02 1316-03	NOVAERUS core DBD plasma technology	US, EU, China	Korea, Japan, India

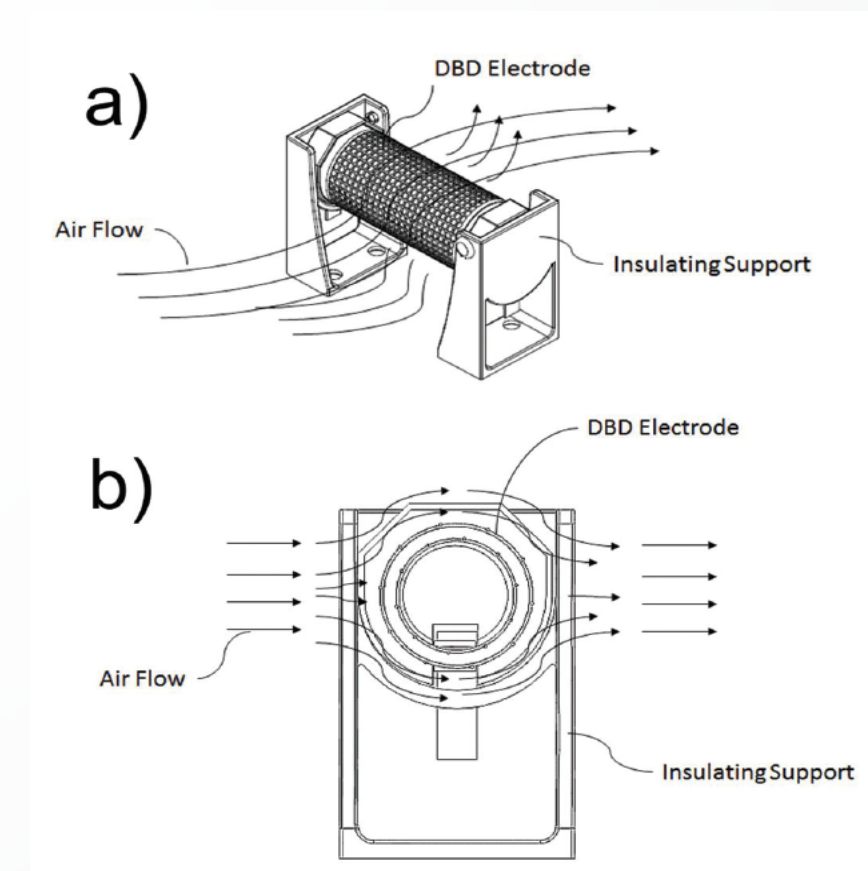

NanoStrike Technology – An Unrivalled Solution

Technology	Key Outcomes											
	Burst Cell of Pathogen	Inactivate Spores	Avoid Future AMR	Sub Second Process Speed	Effective to <1 nm	No Colonization (w/ filters)	No Harmful Biohazards / Gaseous Outputs	Safe / Nontoxic	Consistent “As New” Performance	Lowest Total Cost of Ownership	24 × 7 Operation	Quiet
NanoStrike™ Technology	●	●	●	●	●	●	●	●	●	●	●	●
UVGI	●	●	●	●	●	●	●	●	●	●	●	●
PCO	●	●	●	●	●	●	●	●	●	●	●	●
Unipolar Ionization	●	●	●	●	●	●	●	●	●	●	●	●
ESP	●	●	●	●	●	●	●	●	●	●	●	●
Particulate Filtration	●	●	●	●	●	●	●	●	●	●	●	●
VOC Filtration	●	●	●	●	●	●	●	●	●	●	●	●
Heat	●	●	●	●	●	●	●	●	●	●	●	●
Chemical	●	●	●	●	●	●	●	●	●	●	●	●

● NO ● YES ● N/A

NanoStrike™

technology

QUESTIONS?

